

QTY.	ITEM NO.	Description	PART NUMBER
1	1	FAN PANEL CONDENSER	7050-144-01
2	2	LATCH KEY ALLEN HEX 8mm SOUTHCO E5-6-015-UU1	3545-018
4	3	SET SCREW M5 X 12 ZP	3020-017
4	4	WASHER SPRING M5 ZP	3080-207
2	5	HINGE 96-50-520-50	3540-002
4	6	WASHER M5 ZP	3080-315
1	7	CABLE GLAND M16	2045-049
2	8	CAM E5-6019	3545-003
16	9	RIVET 3/16 RV6900-6-4 GRIP 1.57-6.9	3040-205
1	10	COND FAN INSTALLATION CAY620/700T-6Q1	8011-268-01
1	11	ASSY FAN SHROUD PMD190	7150-269

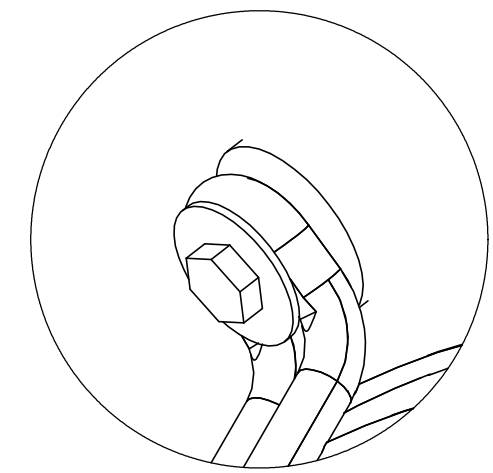

DETAIL A

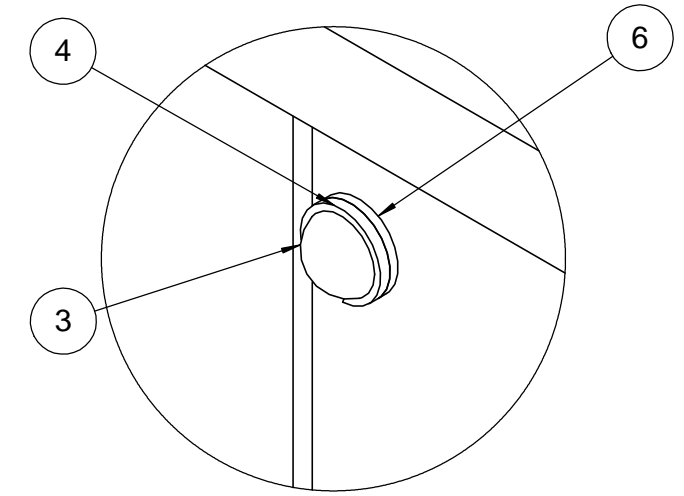

DETAIL B

UNLESS OTHERWISE SPECIFIED
 1. 3rd ANGLE PROJECTION.
 2. DIMENSIONS IN MILLIMETRES.
 3. DO NOT SCALE.
 4. TUBE ENDS MUST BE ROUND AND OF FULL DIAMETER.
 5. TUBE MUST BE CLEAN AND FREE FROM BURRS INSIDE AND OUTSIDE AND SUITABLE OF FOR SOLDERING.
 6. ALL BENDS 90°.
 7. ALL SHEETMETAL'S DIMENSIONS OUTSIDE.

GENERAL TOLERANCES
 (UNLESS OTHERWISE SPECIFIED)
 1. FIN LENGTH ±1.5
 2. <1016mm ±3
 3. >1016mm ±3
 4. ALL TUBES ±0.1/-0
 5. HOLE DIAMETER ±0.5
 6. FLAT PATTERN ±0.5
 7. FOLD (each) ±1°
 8. ANGLES & SQUARENESS ±1°

REV	DESCRIPTION	PCR	BY	DATE
D	PCR2557: Deleted 7050-267-01,7050-268-01,7025-242-01. Qty of 3040-205 was 29	2557	DL	30/04/15
C	LATCHES CHANGED TO HEX TOOL FOR MACHINE GUARDING	1762	NM	21/03/13
B	REPLACED NUTSERTS WITH HEXSERTS AND MADE 7150-269 ASSY	1613	DR	5/01/12
A	DRAWING RELEASE	1613	DR	28/12/11

ActronAir[®]
 ActronAir Pty Ltd
 5 Irvine Place
 Norwest Business Park
 Bella Vista NSW 2153
 PH. +61 2 8814 4000
 A.B.N. 34 002 767 240

This drawing always remains the intellectual property of Actron Engineering Pty Ltd. Copying, Modifying or Distributing without written consent is prohibited.

DESCRIPTION: PMD FAN SHROUD ASSY		
MATERIAL: SEE DRAWING	FINISH:	WEIGHT: Kg
DRAWN BY: D.ROONEY	DRAWN DATE: 28/12/2011	APPROVED BY:

DRAWING NO. 8011-519	REV. D
SCALE: N.T.S.	
SHEET 1 OF 1	THIRD ANGLE PROJECTION